

**THE EVER-CHANGING ELEMENTS.
THE INTENSE ADAPTING.**

ATTACK IT ALL.



HT TRACTOR

You're always looking for more effective ways to work while securing peace of mind along the way. The Oshkosh® HT-Series snow tractor does it all, delivering flexibility, maneuverability and savings that can't be touched by any other Multi-Tasking Equipment. Built for you, inspired by you, the HT-Series accepts a wide range of plows, underbody scrapers and tow-behind brooms to maximize performance.

TAKE BACK THE RUNWAY.

PERFORMANCE FEATURES

Unparalleled Chassis Design

- Tilt cab for superior maintenance access
- New cab-over chassis design puts operators high above the action

Remarkable Flexibility

- Handles everything from plowing and brooming to deicing and scraping
- Quick Hitch system easily links/delinks tow-behind brooms and front plow
- Options for 4 x 4 and 6 x 6 models with optional Oshkosh® ALL STEER® all-wheel steering system
- Supports any tow-behind model broom

Advanced Maneuverability

- ALL STEER performs u-turns in under 75 ft. (23 m), wall to wall with a 24 ft. (7 m) plow and tow-behind broom; compare to Multi-Tasking Equipment maximum of 110 ft. (34 m)

Heavy-Duty Construction

- Oshkosh extra heavy-duty
- Corrosion resistant aluminum cab with fiberglass roof and fascia
- Full-length stainless steel piano type door hinges
- 1-piece panoramic reverse slope windshield
- Power windows left and right

SMARTER. BETTER. THE HT TRACTOR.

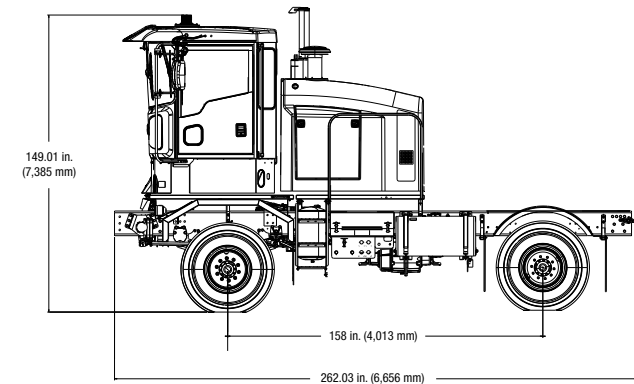

OSHKOSH
AIRPORT
PRODUCTS

HT
TRACTOR

oshkoshairport.com

+1 920 235 9151

*Versions are available with rear axle disconnect, bevel gear center differential with driver-controlled lock or automatic (Dorr-Miller) differential.

CHASSIS

Front Axle: Oshkosh® Model 27K, driver-controlled traction differential and Oshkosh cage ring type steering ends

Rear Axle: Eaton 17427, full floating

Air Brakes, Parking and Emergency:

- Secondary emergency system
 - Modulated split type
 - Auxiliary air inlet, left side
 - Quick drain lanyards on all tanks

Brakes and Service:

- Dual system, air operated mechanical, electronic antilock brake system (4S4M)
- Compressor – 18.7 cfm

Standard Accessories:

- National Standard Plus air ride driver seat, right of center
- Fold up cloth passenger seat
- 55,000 BTU heater/defroster
- Digital climate control
- 12V power outlet (1)
- Cup holders (2)
- Electric remote control heated West Coast type mirrors
- Ether starting aid, thermally protected, ignition switch activated
- Keyed chassis engine
- Quad electric windshield wipers mounted above windshield with intermittent speed control
- Tilt/telescoping steering wheel
- Windshield washer, 6 qt. (5.7 L)
- High idle cruise control

Instrumentation: Oshkosh Command Zone™ LCD dash pod on steering column

Equipment:

- Backup alarm
- Dual 125 gal. (473 L) fuel tanks
- Flat top steel front fenders
- Full catwalks
- Heated fuel/water separator
- Maintenance/daily check cluster, left hand side

Cooling System:

- Radiator core – fin and tube type with deaeration system
- Horizontal flow
- Frontal area – 1,080 in.² (6,967 cm²)
- Fan – temperature-controlled hydrostatic fan drive

Drive Engine:

- Cummins ISX 11.9 L in-line 6 cylinder, 4 cycle
- Displacement – 729 in³ (11.9 L)
- Horsepower – 385 @ 1,800 rpm
- Peak torque – 1,450 lbs.-ft. @ 1,200 rpm
- Governed rpm – 2,100

Electrical System:

- Alternator – 200A, chassis engine driven
- Lighting and starting – 12V each
- Battery – (4) 12V, 950 CCA each @ 0°F (-18°C), 3,800 CCA total

Frame:

- Single formed channel made of carbon manganese steel, heat-treated
- Yield strength – 120,000 psi (827 Mpa) minimum
- RBM – 2,818,000 in.-lb. per rail
- Front frame extension – 24 in. (610 mm)
- Rear tow hooks (2)

Lighting:

- Cab-mounted headlights with turn signals
- Clearance and marker lights to comply with federal regulations
- Engine compartment lights
- Fender-mounted headlights and turn signals
- Roof-mounted strobe light

Steering System:

- Sheppard XD120 integral hydraulic power gear
- Chassis hydraulics warning system – low level/high temperature

Front Suspension:

- Hotchkiss, semi-elliptic spring
- Rating – 29,000 lbs. (13,154 kg)

Rear Suspension:

- Hotchkiss, semi-elliptic spring
- Rating – 23,000 lbs. (10,433 kg)
- Tires: 395/85R20, 20 ply

Transfer Case*:

- Oshkosh 55000 Series, rear axle declutch
- 2.66:1 and 0.98:1 ratios

Transmission: Allison® Rugged Duty Series, 4-speed electronic

Vehicle Ratings at Axle Hubs:

- Front – 29,000 lbs. (13,154 kg)
- Rear – 23,000 lbs. (10,433 kg)
- Total – 52,000 lbs. (23,587 kg)

Wheelbase: 158 in. (4,013 mm)

Wheels:

- Steel disc
- 20 x 10 in. (508 x 254 mm)

OPTIONS

Accessories:

- Integral A/C
- Heated windshield
- Side window wipers

Drive Train:

- Cummins 425, 500 engines
- 27K front axle rating
- 46K, 52K or 58K rear tandem axles
- Oshkosh ALL STEER® electronic all wheel steering system (23K or 26K single axle; 46K or 52K rear tandem only)
- Driver controlled and automatic lock/unlock transfer case

Electrical System:

- HID and other lighting packages
- On-board battery charger (20A self regulating)
- 270A alternator

Frame and Chassis: Single side fuel fill