

**THE PILED-UP RUNWAY. YOUR PACKED MIND.
CLEAR IT ALL.**



H-SERIES BLOWER

When you take to the runway with the Oshkosh® H-Series™ blower, you respond with power. Arming yourself with the exclusive Oshkosh high-speed blower lets you throw an incredible 5,000 tons of snow per hour, with a cast distance up to 200 feet. The H-Series blower unleashes performance that's as forceful as it is adaptable and accommodating.

TAKE BACK THE RUNWAY.

PERFORMANCE FEATURES

Heavy-Duty Construction

- Oshkosh® heavy-duty single piece frame
- Oshkosh designed and tested transfer case/axles
- Proven 2-stage design snow blower head
- Variable speed hydro static ribbon for high-speed snow removal
- Oshkosh ALL STEER® system
- Oshkosh Command Zone™ CAN control system with self diagnostics
- Corrosion resistant aluminum cab with fiberglass roof and fascia
- Full-length stainless steel piano type door hinges
- EPA 2010 compliant drive engine

Superior Visibility

- Elimination of corner posts opens view of the runway
- Quad electric windshield wiper system
- 55,000 BTU heater/defrost system with digital climate control
- Rear three-quarter windows eliminate blind spots
- Light bars are placed out of sight lines
- Lower front windows open up view of attachments
- 1-piece panoramic reverse slope windshield
- Tinted safety glass

Built-In Control and Improved Operator Safety

- 70 in. (1,778 mm) wide cab
- 2 full-size seats for driver and supervisor/training officer
- 2 doors, power roll-down windows and cup holders
- Blower clutch engages only at safe speeds
- Emergency stop button for blower engine and blower head
- Joystick operates only when driver is ready

POWER. INTELLIGENCE. THE H-SERIES BLOWER.

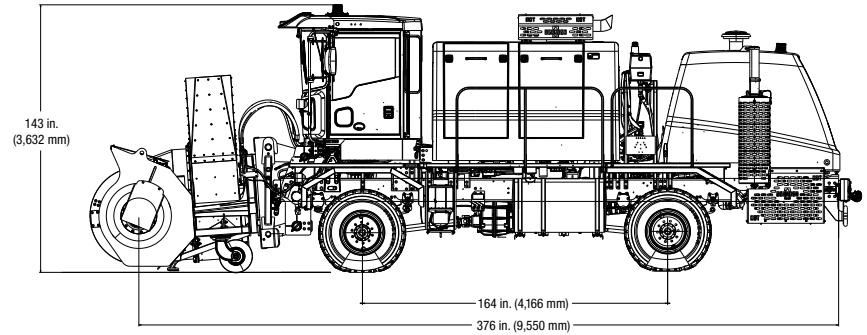

OSHKOSH
AIRPORT
PRODUCTS

**H-SERIES
BLOWER**

oshkoshairport.com

+1 920 235 9151

*Versions are available with rear axle disconnect, bevel gear center differential with driver-controlled lock or automatic (Dorr-Miller) differential.

CHASSIS

Front Axle:

- Oshkosh® Model 27K, single reduction with special heat-treated alloy steel shafts, driver-controlled traction differential and Oshkosh cage ring type steering ends
- 6.17:1 ratio

Rear Axle:

- Eaton 17427, full floating, single reduction with special heat-treated alloy steel shafts and driver-controlled traction differential
- 6.14:1 ratio

Air Brakes, Parking and Emergency:

- Secondary emergency system – modulated split type
 - Auxiliary air inlet, left side
 - Quick drain lanyards on all tanks

Brakes and Service:

- Dual system, air operated mechanical
- Electronic antilock brake system (4S4M)
- Compressor – 15.7 cfm

Standard Accessories:

- National Standard Plus air ride driver seat, right of center
- 55,000 BTU heater/defroster
- Digital climate control
- 12V power outlet (1)
- Cup holders (2)
- Electronic engine controls with on-board diagnostics integral with Oshkosh Command Zone™ system
- Electric remote control heated West Coast type mirrors
- Fresh air type heater and defroster
- LCD dash display
- Light bars
- Quad electric windshield wipers mounted above windshield with intermittent speed control
- Side window defrosters
- Tilt/telescoping steering wheel
- Windshield washer, 6 quarts (5.7 L)

Instrumentation:

- Oshkosh Command Zone LCD dash pod on steering column
- Chassis and blower head functions and icons

Equipment:

- Dual 125 gal. (473 L) fuel tanks
- Full catwalks
- Heated fuel/water separator
- 1-piece molded fiberglass tilting engine cover, carrier engine

Drive Engine:

- Cummins ISX 11.9 L in-line 6 cylinder, 4 cycle
- Displacement – 729 in.³ (11.9 L)
- Horsepower – 350 @ 1,800 rpm
- Peak torque – 1,350 lbs.-ft. @ 1,200 rpm
- Governed rpm – 2,100

Electrical System:

- Alternator – 200A, chassis engine driven
- Lighting and starting – 12V each
- Battery – (4) 12V, 950 CCA each @ 0°F (-18°C), 3,800 CCA total

Frame:

- Single formed channel made of carbon manganese steel, heat-treated
- Yield strength – 120,000 psi (827 Mpa) minimum
- RBM – 2,818,000 in.-lb. per rail
- Construction – Grade 8 flanged bolts and flanged locknuts

Lighting:

- Cab-mounted headlights with turn signals
- Clearance and marker lights to comply with federal regulations
- Fender-mounted headlights and turn signals
- Roof-mounted strobe light
- Dual stop, tail, turn signal lights (LED) at rear

Steering System:

- Sheppard XD120 integral hydraulic power gear
- Chassis hydraulics warning system – low level/high temperature

Suspension:

- Front – Hotchkiss, semi-elliptic spring
- Rating – 27,000 lbs. (12,247 kg)
- Rear – Hotchkiss, semi-elliptic spring
- Rating – 18,000 lbs. (8,165 kg)

Tires: 395/85R20, 20 ply

Transfer Case*:

- Oshkosh 55000 Series, rear axle de clutch
- 2.66:1 and 0.98:1 ratios

Transmission:

- Allison® Rugged Duty Series, 4-speed electronic

Vehicle Ratings at Axle Hubs:

- Front – 27,000 lbs. (12,247 kg)
- Rear – 23,000 lbs. (10,433 kg)
- Total – 50,000 lbs. (22,680 kg)

Wheelbase:

- 164 in. (4,166 mm)

Wheels:

- Steel disc
- 20 x 10 in. (508 x 254 mm)

OSHKOSH BLOWER HEAD AND POWER TRAIN

Clutch:

- Hydraulic SAE No. 1 housing, engage/disengage
- 14 in. (356 mm) 3 plate

Drop Box:

- Oshkosh Single Speed
- 2.65:1 ratio
- Lubrication – pressurized system

Blower Engine (4 Cycle):

- Caterpillar, C-18, in-line 6 cylinder, 4 cycle
- Displacement – 1,105 in.³ (18.1 L)
- Horsepower – 575 @ 2,100 rpm
- Peak torque – 1,938 lbs./ft. @ 1,400 rpm
- Governed RPM – 2,250
- Heated fuel/water separator

Ribbon Auger:

- 56 in. (1,422 mm) diameter
- Hydraulic override and relief
- Reversible ribbon drive

Impeller:

- 59 in. (1,499 mm) diameter, 5 blades, 2 shear bolts in impeller shaft flange, impeller housing liner
- 6:1 planetary reduction

Head:

- 10 in. (254 mm) dual steel caster wheels
- T-1 steel cutting edge
- 30 in. (762 mm) discharge chute
- Abrasion resistant skid shoes
- Removable ribbon flights

Cooling System:

- Radiator core (auxiliary) – fin and tube type with deaeration system
- Fan – temperature controlled clutch
- Spin on coolant filters
- Silicone radiator and heater hoses

BLOWER OPTIONS

Blower Head:

- Rubber tire casters with weight transfer system
- Spot casting loading chute

Blower Engine: Caterpillar C18 high speed, 700 hp

CHASSIS OPTIONS

Accessories

- Integral A/C
- Heated windshield
- Side window wipers

Drive Train:

- Cummins 385, 425, 500 engines
- 29K front axle rating
- Oshkosh ALL STEER® electronic all wheel steering system (23K, and 26K rear only)
- Driver controlled and automatic lock/unlock transfer case

Electrical System:

- HID and other lighting packages
- On-board battery charger (20A self regulating)
- 270A alternator

Frame and Chassis:

- Single side fuel fill
- Centralized side drain kit